

Cladding Attachment and Support



All types of cladding can be used with ROXUL COMFORTBOARD™ 80 and ROXUL COMFORTBOARD™ 110 in a split-insulation wall assembly. The strategy to attach the cladding will depend on the weight and support requirements for the cladding. Most claddings can be attached directly to vertical strapping, which is in turn attached through the insulation to the primary structure.

Structural Considerations

This cladding attachment system uses vertical strapping (i.e. furring), on the front face of the exterior insulation, fastened with long screws through the exterior insulation and into a framed wall. The cladding is then attached and supported with separate fasteners through the strapping. The bending resistance from the screw (when installed into the sheathing and studs), coupled with a truss system, where the fasteners take tension loads and the compression loads are resisted by the bearing of the strapping on the insulation layer, provide the primary support for the cladding. Additionally, the friction between the insulation and the strapping and sheathed wall (created by the force applied by the fasteners) also provides some vertical load resistance.

This system can be used effectively for claddings with weights up to **15 lbs/ft² (73 kg/m²)**, excluding the weight of the insulation. Within this limit, the screw size and installation will vary depending on the cladding weight (see next page). Claddings that weigh over 15 lbs/ft² should be attached using an engineered approach specific to the cladding type and weight. Though cladding weight will generally govern the cladding attachment structural requirements, the potential forces generated by wind as well as seismic activity should also be considered in the structural design. These forces exerted on the cladding will cause increased load on the system components and in particular the screw fasteners.

In addition to cladding weight, stud spacing of the backup wall, sheathing type and thickness, and exterior insulation thickness and type will all affect the required fastener spacing, size, and minimum embedment into the backup wall, as well as the strapping thickness and width. Furthermore, the potential wind loads and seismic activity associated with the location will also impact design. Note that this structural system relies on the increased pullout strength of large screws. For this reason, **nails are not recommended** for use in this application unless designed for a specific project by an engineer.

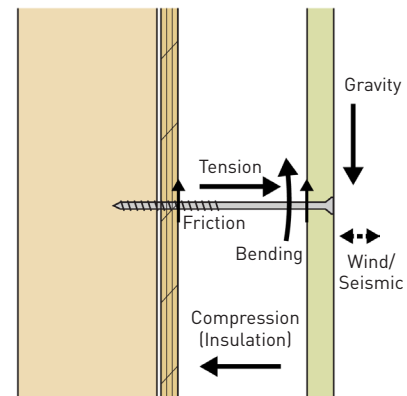
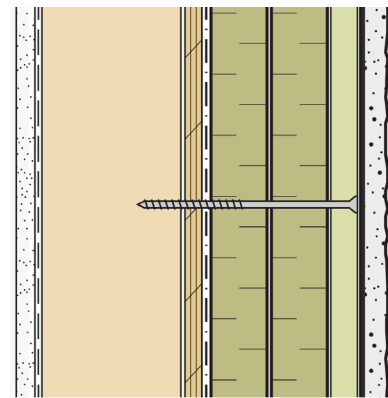

Service Load State (Section View)

Cladding Weight

Cladding weights for the purpose of the structural calculations are categorized as **Light** (less than 5 lbs/ft² [24.5 kg/m²]), **Medium** (5 to less than 10 lbs/ft² [24.5–49 kg/m²]), **Heavy** (10–15 lbs/ft² [49–73 kg/m²]), and **Very Heavy** (over 15 lbs/ft² [73 kg/m²]) weight cladding. The approximate weight and category for various common cladding types is shown below. Each cladding type will have different weights for different brands and cladding arrangements, so the specific cladding weight should be determined from product technical data to confirm which category it is in.



Strapping

In general, the most appropriate strapping will be plywood strapping ripped to width, since the requirements for large screws at close spacings may risk splitting strapping made from dimensional lumber, particularly thinner strapping. Larger dimension lumber strapping such as nominal 1x3 or nominal 1x4 may also be adequate in this application. The required strapping thickness and width for structural purposes is a function of the cladding weight and insulation density. Thicker strapping is often recommended in order to reduce potential bowing or twisting of the strapping between fasteners as it is installed and as cladding is attached. Wider strapping generally reduces the potential compression of the insulation by spreading the force of the fastener tension over more area insulation behind the wider strapping. Confirm with the cladding manufacturer the correct size and configuration of the strapping for specific cladding products.

Screws

Screws used to attach the strapping through the insulation should be either stainless steel or galvanized with a coating rated to 2000 hour salt spray per ASTM B117, as they will be exposed to the exterior environment and should be protected from corrosion to ensure long term durability. Always ensure the screw type is compatible with both the strapping material (i.e. wood pressure treatment) and the cladding material. This cladding attachment system may require specialty screws in order to accommodate large load torques when installed through thick insulation into the backup wall. One important constructability consideration is the use of screws with a countersunk head so that the screw head can be embedded into the front face of the strapping and out of the way of cladding materials and attachment accessories.



Backup Wall and Minimum Fastener Embedment

The stud spacing of the exterior framed walls will govern the horizontal spacing of the strapping and fasteners, as all fasteners through exterior insulation should be installed through the exterior sheathing into the studs. Closer stud and strapping horizontal spacing (i.e. maximum 16" o.c.) provides additional support for the cladding and, therefore, may allow less frequent vertical screw placement. For wider spaced framing (i.e. 24" o.c. horizontal spacing) closer vertical spacing of screws may be required.

Generally, the screws used to fasten the strapping in place are installed through wood sheathing and into the wood framing in the backup wall with standard plywood or oriented strand board sheathing used as the sheathing material. For ease of construction, consider using markers or snap lines on the outside face of wall membrane in line with the stud framing in order to clearly indicate the correct location of screws into the backup wall. Note that screws that do not penetrate into the framing should not be removed for repositioning, as screw holes created in the sheathing membrane may increase the risk of water ingress and/or air leakage in the wall assembly. These screws should be left in place, with a secondary screw installed into the stud at the same location.

The minimum screw embedment length is measured from the outside face of the wood sheathing. Fasteners should at a minimum fully penetrate through the exterior sheathing (Fastener Tables include a minimum fastener embedment of 1", to account for up to 3/4" exterior sheathing). Additionally, the minimum embedment length only accounts for the non-tapered portion of the screw where the screw threads are at the full diameter, and does not include the front tip of the screw. As a rule of thumb, approximately the front 1/4" of the screw should be ignored in determining the appropriate screw length. Contact the screw manufacturer for further information.

Deflection

Testing has shown that minor deflection of the strapping and cladding may be experienced for wall assemblies with heavy weight cladding. In most cases, the deflection is constrained to less than 1/32" for typical heavy weight cladding loads. Claddings that may be prone to cracking, such as stucco or adhered stone, should be installed so as to reduce inside corners and irregular shapes, and wherever possible should be segmented into smaller areas across the face of the wall assembly using crack control cuts or hidden joints.

Potential deflection may be reduced by installing screws at an upwards angle into the backup wall. This configuration allows the support system to rely more readily on the truss action of the screw tension and insulation compression, rather than screw bending resistance and friction. In this way, the cladding attachment system is installed with the potential screw deflection already in place—even before cladding loading. This greatly reduces the potential for downward movement that may occur when supporting heavy weight cladding on strapping. It should be noted that the fastener tables in this guide do not account for screws being installed at an upwards angle and, as a result, specific structural design should be engineered for wall assemblies where this configuration is desired (see also page 10).

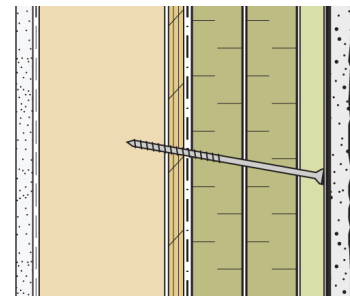

Screw at Upward Angle
(Section View)

Fastener Tables

The following pages include fastener requirements for attaching strapping over ROXUL COMFORTBOARD™ 80 and ROXUL COMFORTBOARD™ 110 using long screws. The tables are organized by cladding weight, with fastener requirements shown for insulation thicknesses up to 8". Note that the following tables are not applicable for insulation thicknesses over 8" - specific structural design is required for this condition. Illustrations of each aspect of the fastener and strapping installation requirements is shown below.

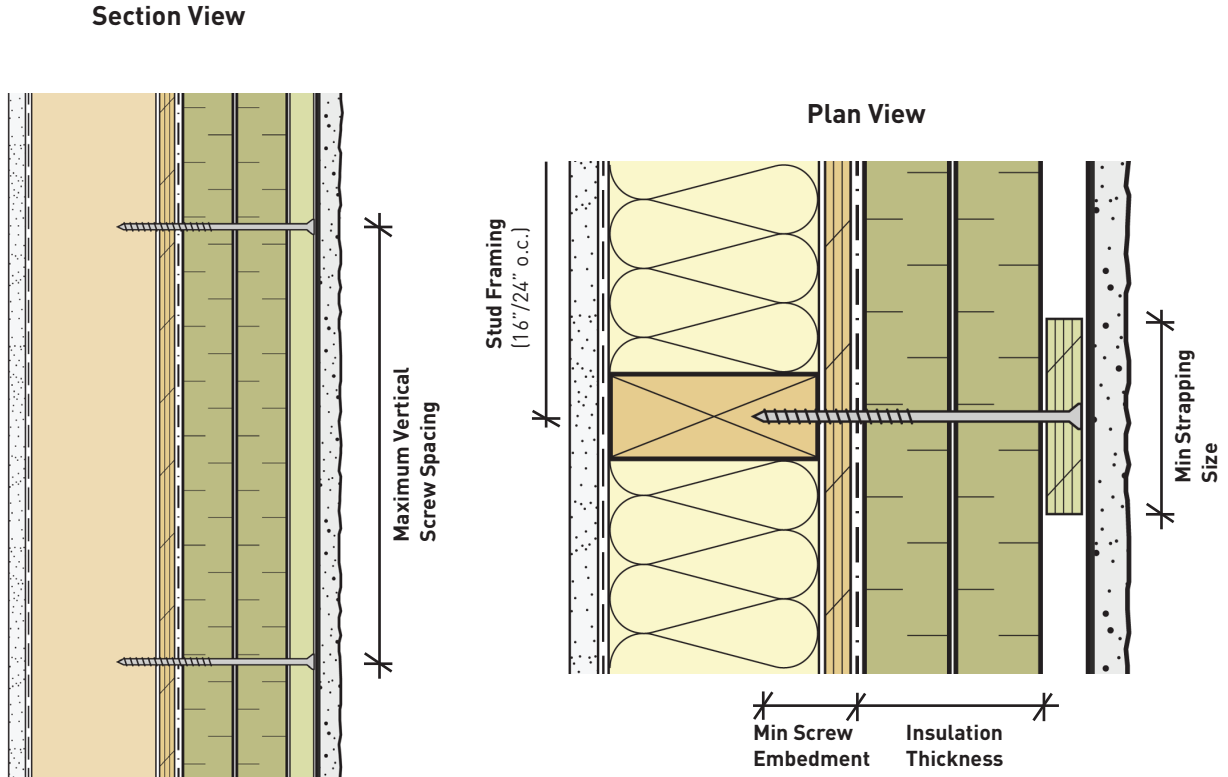

The table below outlines the assumed structural properties for the materials used in this cladding support system.

Assumed Structural Properties		
Rigid mineral wool minimum compressive strength		Stainless/galvanized steel screw allowable tensile strength
COMFORTBOARD™ 80	COMFORTBOARD™ 110	
439psf (21kPa) @ 10% compression, ASTM C165 testing	584psf (28kPa) @ 10% compression, ASTM C165 testing	60,000 psi (414 MPa)

Fastener Tables

Light Weight Cladding

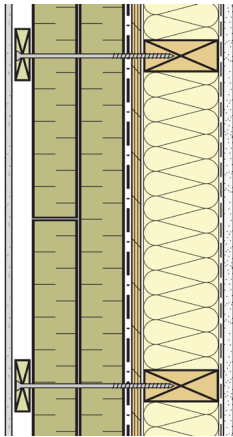

Fastener/Strapping Installation Requirements				
ROXUL COMFORTBOARD™ Thickness	Maximum Vertical Screw Spacing	Minimum Screw Size	Minimum Screw Embedment	Minimum Strapping Size
Light Weight Cladding Below 5 lbs/ft² - 16" o.c. Stud Framing				
1" - 2"	24"	#10	1"	3/8" x 2-1/2"
>2" - 8"	16"			
Light Weight Cladding Below 5 lbs/ft² - 24" o.c. Stud Framing				
1" - 2"	24"	#10	1"	3/8" x 2-1/2"
>2" - 8"	16"			

Medium Weight Cladding

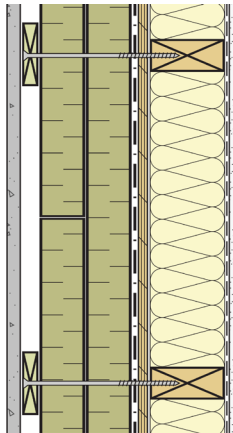

Fastener/Strapping Installation Requirements				
ROXUL COMFORTBOARD™ Thickness	Maximum Vertical Screw Spacing	Minimum Screw Size	Minimum Screw Embedment	Minimum Strapping Size
Medium Weight Cladding Between 5 lbs/ft² and 10 lbs/ft² - 16" o.c. Stud Framing				
1" - 4"	16"	#12	1"	1/2" x 3-1/2"
>4" - 8"	12"			
Medium Weight Cladding Between 5 lbs/ft² and 10 lbs/ft² - 24" o.c. Stud Framing				
1" - 4"	12"	#12	1"	1/2" x 3-1/2"
>4" - 8"	8"			

Heavy Weight Cladding

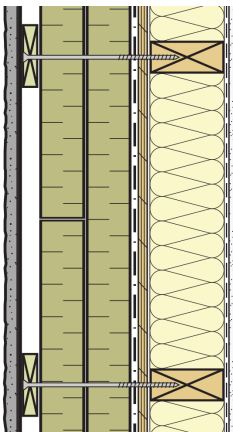

Fastener/Strapping Installation Requirements				
ROXUL COMFORTBOARD™ Thickness	Maximum Vertical Screw Spacing	Minimum Screw Size	Minimum Screw Embedment	Minimum Strapping Size
Heavy Weight Cladding Between 10 lbs/ft² and 15 lbs/ft² - 16" o.c. Stud Framing				
1" - 2"	16"	#14	1-1/2"	3/4" x 3-1/2"
>2" - 8"	12"			
Heavy Weight Cladding Between 10 lbs/ft² and 15 lbs/ft² - 24" o.c. Stud Framing				
1" - 2"	10"	#14	1-1/2"	3/4" x 3-1/2"
>2" - 4"	8"			
>6" - 8"	6"			

Other Considerations

Insulation Board Installation

Installation of one or multiple layers of ROXUL COMFORTBOARD™ 110 requires a stepped approach, as each insulation board should be attached using only the strapping as much as possible, so as to reduce the number of fastener penetrations through the insulation. This approach is most easily completed using following installation procedure (see illustration)

1. Install the starter course of insulation using the strapping fastened at the bottom edge and held upright in place as needed. Insulation boards should be installed with the vertical edges offset 8" from the strapping so that each board (48" wide) will be secured behind 3 separate straps.
2. Place the insulation behind the strapping and "stack" it on the starter course, with screws installed along the strapping through the insulation boards as they are installed up to the top edge.
3. Insulation boards in a single layer can be stacked directly above with the course below, and should be offset 16" horizontally between layers if multiple insulation layers are used.

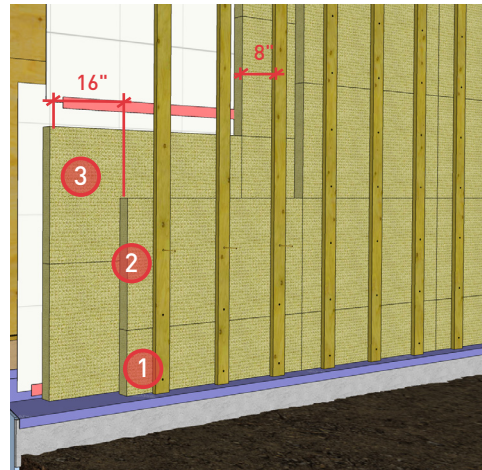

An alternative installation approach is to use one or two fasteners with washers to pin the insulation boards in place before the strapping is installed.

Shear Block Option

Potential deflection for heavy weight cladding may be reduced by using deflection blocks the top of the strapping pieces, or by installing screws at an upwards angle into the backup wall. The approach with deflection blocks uses pressure treated dimension lumber blocking, installed at the top of the strapping either at the rim joist or at the top of the wall, in order to "hang" the strapping (see illustration). This provides a solid wood support mechanism and minimizes the deflection movement of the cladding. Note that the blocking attachment should be designed to provide 100% of the vertical support for the cladding in order prevent loading on the screws at portions of the strapping without deflection blocks and the resulting potential vertical movement. The structural design in this section does not account for installation of deflection blocks at the top of the strapping, and therefore specific structural design should be completed for wall assemblies where this configuration is desired.

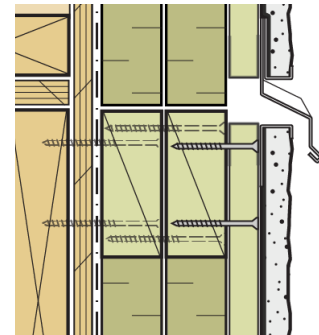

Rainscreen Cavity

A ventilated wall cavity outboard of the rigid insulation is recommended in all climate zones. The ventilated cavity allows air flow behind the cladding on the exterior side of the insulation preventing inward vapor drive and meeting the requirements of a rainscreen assembly. Ventilated wall cavities are strongly recommended where vapor-open exterior insulations are used in conjunction with absorptive claddings like brick and in warmer climates where the predominant vapor flow is inwards. The benefits of ventilation also include reduced cladding temperatures in warm climates, which helps reduce heat gain.

Sample Structural Calculation

Below is an example of a generic structural calculation. It is intended to show the design parameters and considerations included in the calculations used to produce the tables in this guide; however, it is not intended to provide a basis for calculation for specific cladding attachment design. Note that the calculations include various assumptions in order to begin the design work, and rely on engineering judgement based on industry research and common construction practices. For simplicity, consideration of the forces generated by wind and potential seismic activity are not shown, though they are considered in the calculations used to generate the Fastener Tables. Structural calculations for specific configurations that vary from the those provided in the Fastener Tables should be completed by a registered professional.

Pa must be less than or equal to **Pr-bend + Pr-truss**

Where:

Pa = applied vertical force per screw due to cladding dead load (lbs)

Pr-bend = screw bending maximum vertical force resistance (lbs)

Pr-truss = truss action maximum vertical force resistance (lbs)

and

Mr-bend = screw bending maximum moment resistance (lb-in)

Mr-truss = truss action maximum moment resistance (lb-in)

L = insulation thickness/screw moment arm length (in)

Δx = assumed initial insulation compression due to strapping (in)

S = insulation compressive strength at given insulation compression (psf)

F = insulation compressive force due to strapping compression

*note vertical force resistance due to friction is assumed negligible

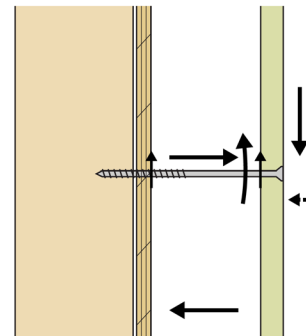

Example: 15 psf cladding, 4in exterior insulation, 16in o.c. stud framing

Assumed fastener spacing @ 16in horiz. x 12in vert.

Pa = 15psf x 1.33ft x 1ft = **20lbs**

Pr-bend

Mr-bend for 0.25in diameter steel screw (calculations not shown) = 50.8 lb-in

Pr-bend = **Mr-bend/L** = 50.8lb-in/4in = **12.7lbs**

Pr-truss

Δx = **0.125in** assumed max (3% compression of 4in insulation)

S = **172.4psf** (ROXUL COMFORTBOARD™ 110 at 10% compression = 584psf)

F = 172.4psf x (0.3ft x 1ft) (assumed 3.5in wide strapping x 6in vertical compression length) = **25lbs**

Mr-truss = **F** x vertical compression length/2 = **75lb-in**

Pr-truss = **Mr-truss/L** = 75.4lb-in/4in = **18.9lbs**

Pr-bend + Pr-truss = 12.7lbs + 18.9lbs = **31.6lbs > Pa**

*For more information please see engineering report *Structural Testing of Screws through Thick Exterior Insulation* available on the ROXUL website.

A Global Leader

ROXUL Inc. is a subsidiary of ROCKWOOL International A/S, the world's leading supplier of innovative products and systems based on stone wool. ROCKWOOL International A/S is a publicly held company, which trades on the NASDAQ OMX Nordic Exchange Copenhagen. Operating 28 factories in 18 countries, the ROCKWOOL Group employs more than 10,000 people and features a global network of sales companies, trade offices and dedicated commercial partners. ROXUL® products provide superior thermal and acoustical value and are fire resistant, water repellent, non-corrosive, and resistant to mold.

For more, visit roxul.com

ROXUL is the Better Insulation Choice

ROXUL insulation is innovative, offering a world of green features. Sustainability is a fundamental pillar of our philosophy at ROXUL. We are proud to have our products used in projects targeting LEED® certification, as they can contribute both to energy efficiency and materials credits. For more information, we recommend reading the applicable LEED Reference Guide for detailed descriptions of all credits.

Find out more about how we can assist with your design projects.

A ROXUL representative will be pleased to provide you with further details on the products described in this brochure, and can also update you with comprehensive information on the entire line of ROXUL products.

Visit our website at roxul.com, or contact us directly at **1-800-265-6878**.



Environmentally Sustainable

Our stone wool production process uses some of the most advanced technology available. The last decade has seen a new generation of ROXUL manufacturing advancements designed to lower our environmental footprint. These endeavors have included:

- the capture and recycling of rainwater;
- reduction in energy consumption;
- recycling of raw materials back into the production process;
- the use of natural lighting in our facilities; and
- repurposing water used during the manufacturing process.

We are proud that these steps have minimized our impact on the environment and surrounding community resources. But our green programs don't stop there.

ROXUL insulation is created using naturally occurring inorganic raw materials, and reuses waste from other manufacturers as well as from our own plants. Stone wool insulation is non-combustible and achieves its thermal performance without the use of blowing agents. Therefore, our products do not off-gas over time. This feature alone makes a substantial contribution to a cleaner environment.

To remain efficient and environmentally friendly, each ROXUL plant uses a varying combination of new and recycled content. For example, as a direct result of producing less manufacturing waste during the production process, we are able to use up to 40 per cent recycled content. Our continuing effort to improve our overall efficiencies further solidifies our commitment to environmental stewardship within our organization.



Sound Absorbent



Fire Resistant



Water Repellent



Easy Fit



Made from Stone



Recycled Content